

## SDI-12 ANEMOMETER

The TBSWS1 is a versatile anemometer with SDI-12 interface. It provides two operation modes. It can either measure momentary wind speed, or measure average wind speed, maximum wind speed and minimum wind speed over a configurable logging period.

It is based on a rugged aluminium body with polyester coating. Precision, low friction bearings and a stainless steel shaft make it a very reliable device. The use of a magnetic rotary encoder as sensor element eliminates the disadvantages associated with reed switches used in conventional anemometers.

Optionally, the anemometer can be delivered with an integrated heating for de-icing.



TBSWS1 SDI-12 Anemometer

### Features

- Measurement range: 0,5 m/s to 55 m/s
- Accuracy: typ.  $\pm 2\%$ ; max.  $\pm 3\%$
- Polyester coated aluminium body
- Precision stainless steel bearings
- High resolution magnetic rotary encoder
- Measurement response: 1 sec
- SDI-12 Standard V1.3
- Plug and Play
- 6 - 16V supply voltage range
- Advanced measurement mode
- Operating Temperature Range:  
- 40°C ... + 70°C
- Weight: 0,6kg

- Excellent price-performance ratio

### Target Applications

- SDI-12 Sensor Networks

# SDI-12 ANEMOMETER

## Contents

<b>1</b>	<b>INTRODUCTION</b>	<b>3</b>
1.1	MEASUREMENT	3
1.2	PRODUCT SPECIFICATION	5
1.3	CALIBRATION	5
1.4	INSTALLATION	6
1.5	SDI-12	6
<b>2</b>	<b>APPLICATION EXAMPLES</b>	<b>7</b>
<b>3</b>	<b>HARDWARE DESCRIPTION</b>	<b>8</b>
3.1	BASE PART DRAWINGS	8
3.2	CABLE CONNECTION	9
3.3	CABLE REPLACEMENT	10
<b>4</b>	<b>SUPPORTED SDI-12 COMMANDS</b>	<b>10</b>
4.1	SUPPORTED EXTENDED COMMANDS	12
<b>5</b>	<b>ORDERING INFORMATION</b>	<b>13</b>
<b>6</b>	<b>HISTORY</b>	<b>13</b>

## Tables

Table 1: <i>wind speed unit conversion</i>	3
Table 2 – Cable Connection	9
Table 3 – Standard SDI-12 commands	11
Table 4 – Extended SDI-12 Commands	12
Table 5 – Ordering Information	13
Table 6 – History	13

## Figures

Figure 1 – TBSWS1 and other sensors with SDI-12 interface connected to TBS03	7
Figure 2 – TBSWS1 and other sensors with SDI-12 interface connected to Remote Telemetry Unit	7
Figure 3 – Base part drawing	9

# SDI-12 ANEMOMETER

## 1 Introduction

The TBSWS1 is a rugged anemometer with SDI-12 interface. The measurement result can be set to any unit, using extended SDI-12 commands.

For applications in low temperature environment, the anemometer can be delivered with a built in heating for de-icing.

### 1.1 Measurement

The TBSWS1 can output wind speed in any of the units below:

1 kn	= 1 sm/h	= 1,852 km/h	= 0,514 m/s
1 m/s	= 3,6 km/h	= 1,944 kn	= 2,237 mph
1 km/h	= 0,540 kn	= 0,278 m/s	= 0,621 mph
1 mph	= 1,609344 km/h	= 0,8690 kn	= 0,447 m/s

Table 1: *wind speed unit conversion*

1 revolution/second = 256 pulses/s = 0,995m/s

The default output of the wind speed sensor is meter/second (m/s) which then is converted into the required wind speed unit, using a multiplier defined by issuing a extended SDI-12 command.

Supported measurement commands:

**aM! ,aMC! aC! ,aCC! wind speed [m/s]**

the default measurement unit is meter/second, however using an extended SDI-12 command, the result can be changed to any other unit

**Simple mode:**

```
00061
0D0!
0+0.56
```

**Advanced mode 1:**

```
00013
0D0!
0+9999999+9999999+9999999
```

invalid data; the measurement command was issued before the first logging period was completed

```
00013
0D0!
0+1.56+1.85+1.42
```

avg, max, min wind speed of the latest completed logging period

In Advanced mode 1, wind speed is measured every 3 seconds. The measurement values are then averaged over a configurable period which must be a multiple of 3 seconds, up to a maximum of 60 seconds. The averaged values are then collected over a configurable logging period. At the end of the logging period, average wind speed, minimum- and maximum windspeed of the logging period is calculated and stored. Upon a measurement command, the results of the latest, completed logging period will be delivered.

**The anemometer must be continuously powered when it is operated in Advanced mode 1.**

## SDI-12 ANEMOMETER

The SDI-12 data logger shall operate as following:

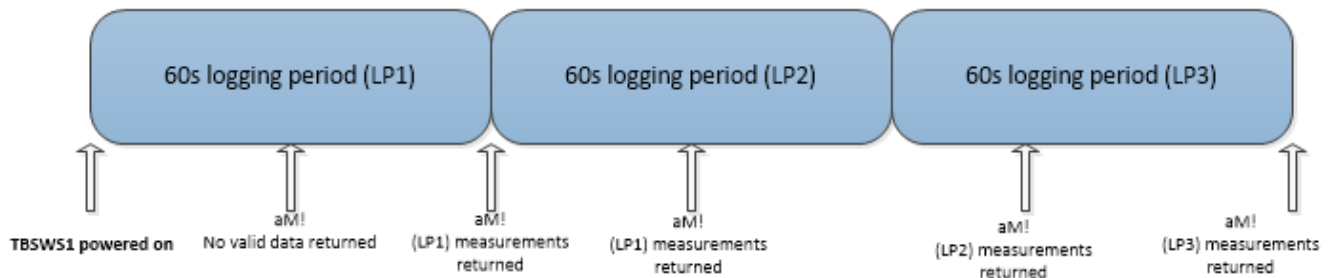

### Advanced mode 2:

00013

ODO!

0+1.56+1.85+1.42

avg, max, min wind speed over 2 consecutive SDI-12 measurements

In Advanced mode 2 the logging period is the time between two consecutive SDI-12 measurements. This is like Advanced mode 1 but logging starts after an SDI-12 measurement and stops when the next measurement is issued. At this point, average, minimum and maximum wind speed are output over SDI-12 and the logging is immediately restarted.

The anemometer must be continuously powered when it is operated in Advanced mode 2.

The SDI-12 data logger shall operate as following:

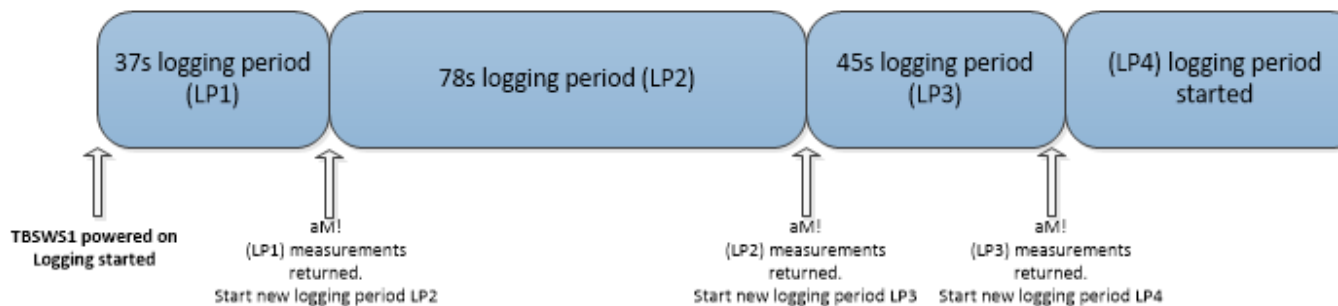

**aM! ,aMC1! aC1!,aCC1!                      temperature [°C,F]**

the default measurement unit is degree Celsius, however using an extended SDI-12 command, the result can be changed to Fahrenheit

### Extended SDI-12 commands:

**aXSASF,+a.aa!                      set multiplier (max. 7 digit+decimal point+sign)**

**aXGASF!                                  query multiplier**

use the multiplier to convert [m/s] into any other unit according to table 2 above. The extended SDI-12 command to set the measurement unit needs to be issued only once during the configuration of the anemometer. The configuration will be stored in non volatile memory. A multiplier value of 1 = [m/s] is the default setting.

Other values:  
 +a.aa = 3.6 output in km/h  
 +a.aa = 1.944 output in knots  
 +a.aa = 2.237 output in mph

**aXST,u!                                  set temperature unit; u= C for °C; u=F for °F**

**aXGT!                                      query temperature unit**

## SDI-12 ANEMOMETER

Use the above command to configure the temperature unit; [°C] is the default setting

### 1.2 Product Specification

- Measurement of wind speed in the range 0,5 m/s to 55 m/s; maximum rating > 70m/s
- Measurement accuracy better  $\pm 0,5$  m/s for wind speeds < 5 m/s; typical  $\pm 2\%$ , maximum  $\pm 3\%$  for wind speeds > 5 m/s
- Operating temperature range: -40 to +70°C
- Relative air humidity range: 0% to 95% (no condensation)
- Internal temperature measurement: -40°C to +80°C,  $\pm 3^\circ\text{C}$  accuracy
- Optional built in heating, PTC type, 12 – 30V,  $\leq 50\text{W}$
- IP protection: IP65
- Body material: aluminium alloy, polyester coating
- Wind cup material: stainless steel 304
- Bearing material: stainless steel 440C
- Weight: 0,6 kg
- SDI-12 interface
- Supply voltage range: 6V to 16V
- Current consumption: 25mA for 1 second in simple mode; avg. 2,5 mA in Advanced mode 1&2; idle < 50 $\mu\text{A}$
- Standard cable length: 3m; any other length upon requirement/order

### 1.3 Calibration

The TBSWS1 does not need any user calibration.

The device is by default calibrated to a wind speed of 0,995 m/s per revolution/s.

**aXSC,+a.aa!**                    **set calibration factor (max. 7 digit+decimal point+sign)**  
**aXGC!**                            **query calibration factor**  
default value is 0,995

Furthermore a default offset of 0,5m/s (starting speed of the anemometer is added to the measurement)

**aXSO,+a.aa!**                    **set offset value (max. 7 digit+decimal point+sign)**  
**aXGO!**                            **query offset value**  
default value is 0,5

It is not recommended to use the above commands, as the unit does not need any user calibration.

## SDI-12 ANEMOMETER

### 1.4 Installation

The TBSWS1 is compatible with any data logger or remote telemetry unit with SDI-12 interface. Refer to the data logger or RTU manual and to chapter 2 and 3 of this datasheet. Chapter 2 refers to the electrical installation; chapter 3 contains a mechanical drawing of the base part of the housing.

The TBSWS1 shall be mounted above any local objects that obstruct wind flow or may cause turbulences. In case of mounting the anemometer on a roof, it shall be placed at least 2 - 3 meters above the roof line.

For the calculation of evapotranspiration in agricultural applications, the anemometer shall be placed 2 meters above ground.

Accordinging metereological and aviation standards, anemometers shall be placed 10 meters above ground.

### 1.5 SDI-12

SDI-12 is a standard for interfacing data recorders with microprocessor-based sensors. SDI-12 stands for serial/digital interface at 1200 baud. It can connect multiple sensors with a single data recorder on one cable. It supports up to 60 meter cable between a sensor and a data logger.

The SDI-12 standard is prepared by

**SDI-12 Support Group  
(Technical Committee)  
165 East 500 South  
River Heights, Utah  
435-752-4200  
435-752-1691 (FAX)  
<http://www.sdi-12.org>**

The latest standard is version V1.3 which dates from July 18<sup>th</sup>, 2005. The standard is available on the website of the SDI-12 Support Group.

More information on SDI-12 is presented in chapter 3.

# SDI-12 ANEMOMETER

## 2 Application Examples

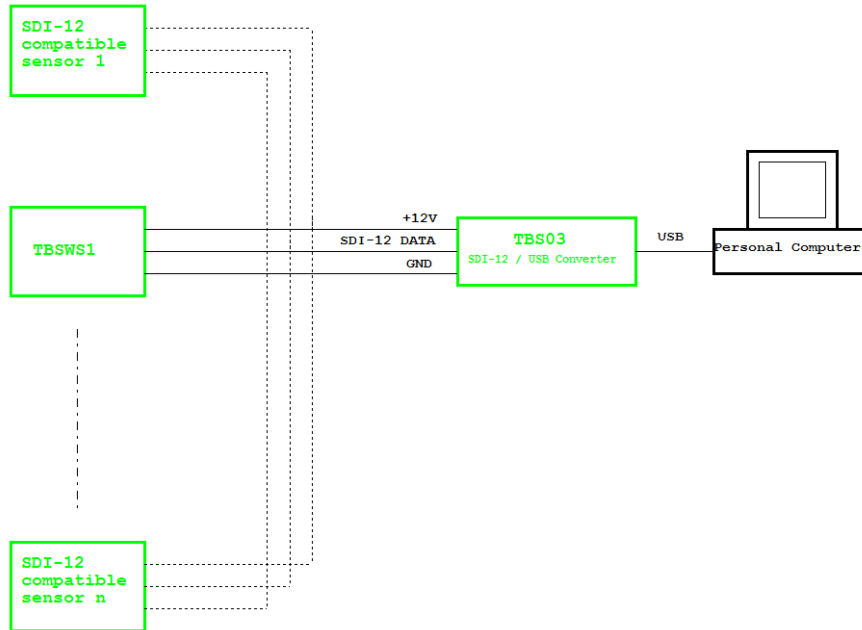

Figure 1 – TBSWS1 and other sensors with SDI-12 interface connected to TBS03 SDI-12 to USB converter; setup for controlling / testing sensors and for PC based data recording

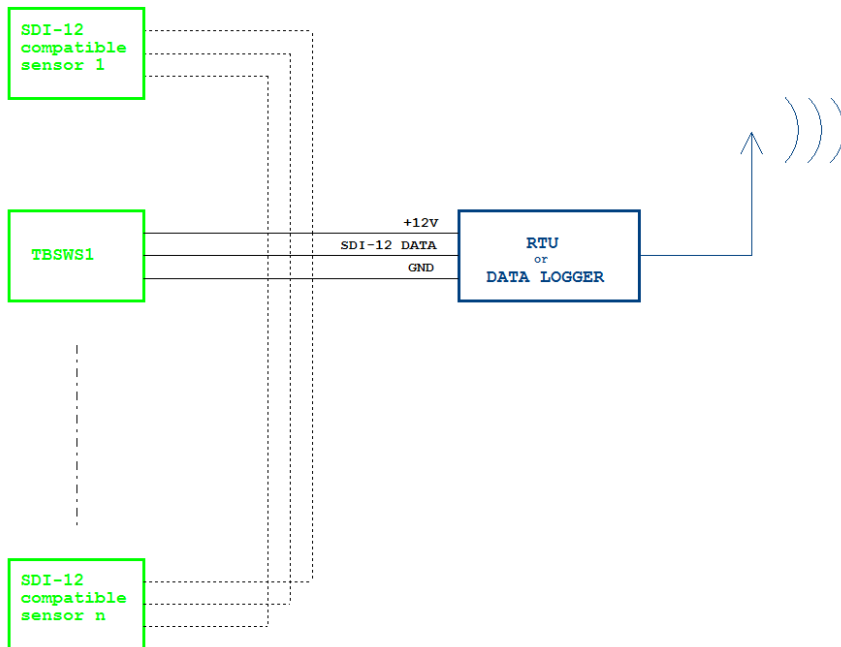
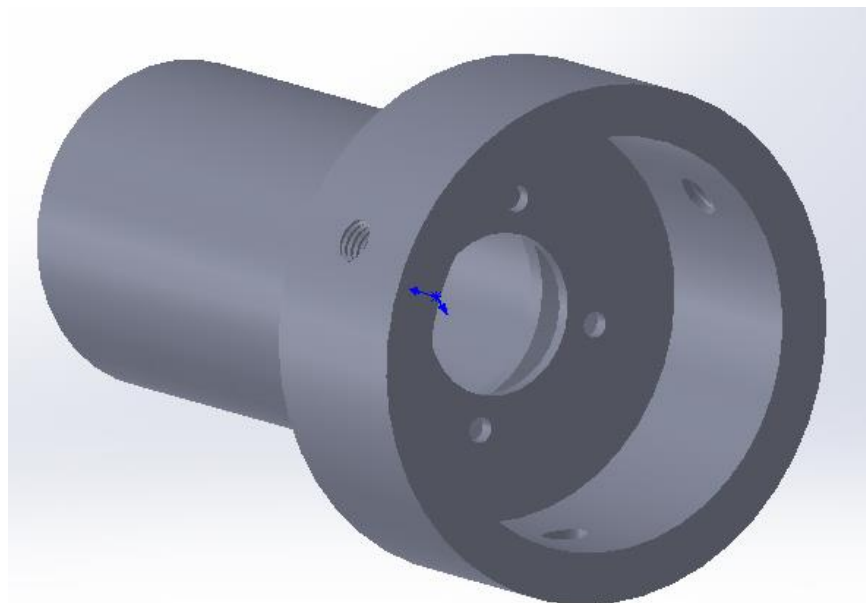
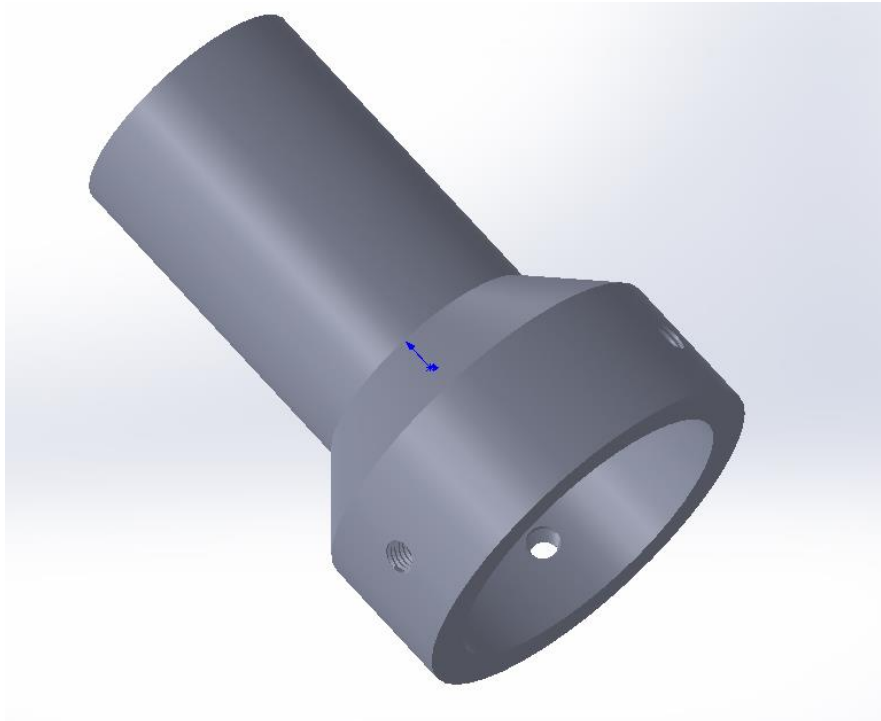

Figure 2 – TBSWS1 and other sensors with SDI-12 interface connected to Remote Telemetry Unit or Data Recorder

## SDI-12 ANEMOMETER

### 3 Hardware Description

#### 3.1 Base part drawings





## SDI-12 ANEMOMETER

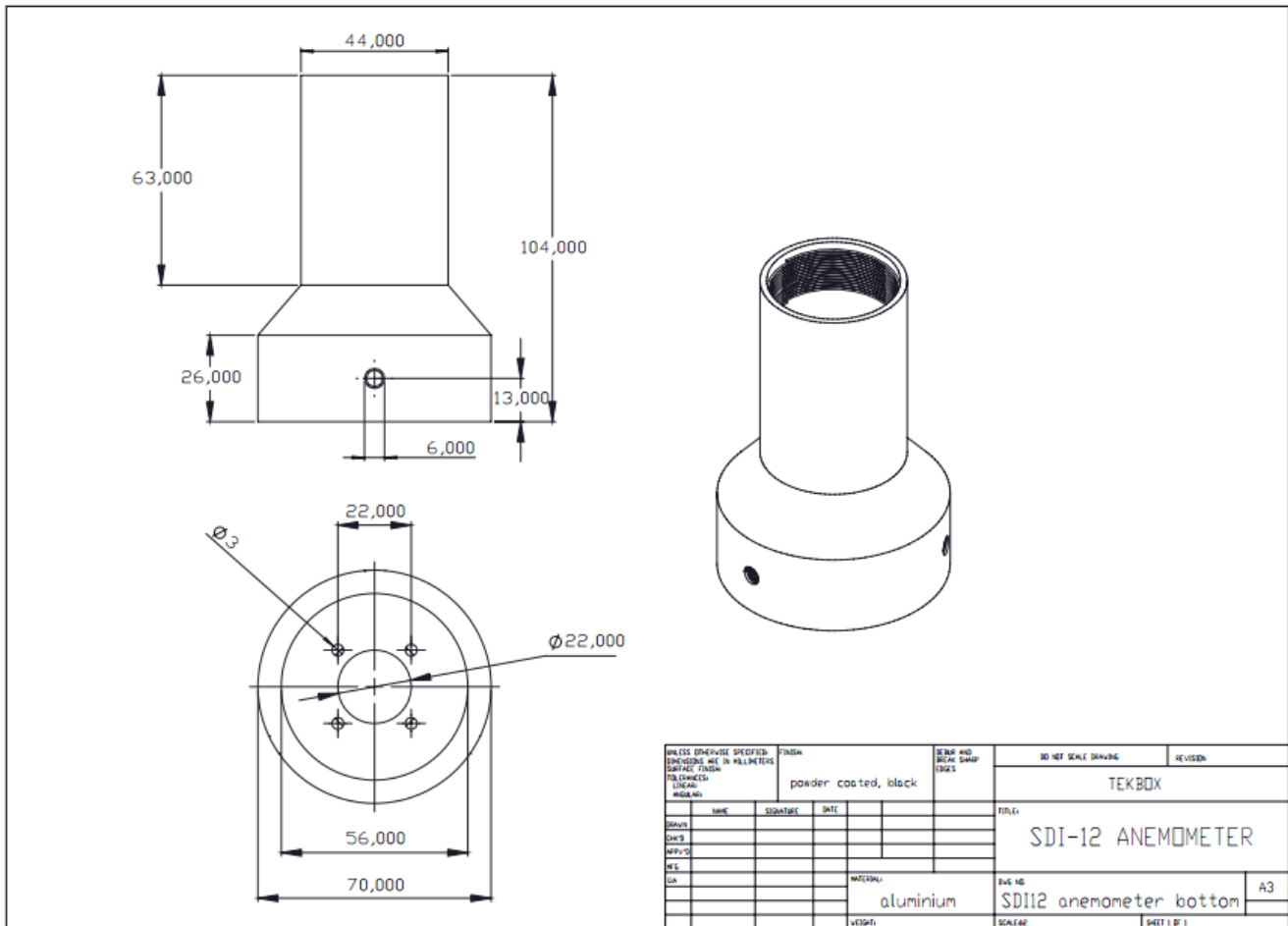

Figure 3 – Base part drawing

The TBSWS1 is designed to be mounted on top of a pole with a diameter in the range of 40 mm to 54mm. In case of diameters below 40mm, simply use longer clamping screws.

### 3.2 Cable Connection

Cable Colour	Signal Assignment
Blue	SDI-12 Power
Yellow	SDI-12 Data
Brown	GND
Black	Shield (GND)

Table 2 – Cable Connection

## SDI-12 ANEMOMETER

### 3.3 Cable Replacement

To replace the cable, proceed as follows:

- 1) Cut the cable 5 cm from the grommet
- 2) Remove the 4 screws of the grommet base plate
- 3) Open the grommet and strip it from the cable; take care not to lose the base plate gasket
- 4) Un-insulate the remaining cable and attach it to a suitable screw terminal block (there is sufficient space inside the housing to accommodate a screw terminal block)
- 5) Un-insulate the ends of the replacement cable, feed it through the grommet and attach it to the other side of the screw terminal block
- 6) Tighten the grommet and fasten the screws of the base plate; don't forget to add the base plate gasket

Alternatively proceed as follows:

- 1) Cut the cable 5 cm from the grommet
- 2) Remove the 4 screws of the grommet base plate
- 3) Open the grommet and strip it from the cable; take care not to lose the base plate gasket
- 4) Hold or clamp the bottom part of the body and unscrew the top section with a wrench
- 5) Unsolder the cable from the PCB
- 6) Feed the replacement cable through the grommet, don't forget to add the base plate gasket
- 7) Solder the replacement cable to the PCB
- 8) Apply suitable Loctite to the thread and screw the top part to the bottom part. Take care not to contaminate or damage the O-ring.
- 9) Tighten the grommet and fasten the screws of the base plate

## 4 Supported SDI-12 Commands

Following commands are supported by the TBSWS1:

Command	Description	Response
<b>a!</b>	Acknowledge Active	a<CR><LF>
<b>al!</b>	Send Identification	a13TEKBOXVNTBSWS11.6<xxxxxx><CR><LF> With <xxxxxx> representing the serial number
<b>aAb!</b>	Change Address	b<CR><LF> Changing the sensor address from a to b
<b>?!</b>	Address Query	a<CR><LF>
<b>aM!</b>	Start Measurement Measures wind speed	Simple mode: measurement of momentary wind speed a0061<CR><LF> Delay: (6) seconds and number of values (1)  Advanced mode 1&2: measurement of average -, maximum – and minimum wind speed a0013<CR><LF>

## SDI-12 ANEMOMETER

		Delay: (1) seconds and number of values (3)
<b>aM1!</b>	Additional Measurement Measures internal temperature	a0011<CR><LF> Delay: (1) seconds and number of values (1)
<b>aMC!</b>	Start Measurement and request CRC Measures wind speed and calculates CRC	Simple mode: measurement of momentary wind speed a0061<CR><LF> Delay: (6) seconds and number of values (1) Advanced mode 1&2: measurement of average -, maximum – and minimum wind speed a0013<CR><LF> Delay: (1) seconds and number of values (3)
<b>aMC1!</b>	Additional Measurement and request CRC Measures internal temperature and calculates CRC	a0011<CR><LF> Delay: (1) seconds and number of values (1)
<b>aC!</b>	Start Concurrent Measurement Measures wind speed	Simple mode: measurement of momentary wind speed a00601<CR><LF> Delay: (6) seconds and number of values (1) Advanced mode 1&2: measurement of average -, maximum – and minimum wind speed a00103<CR><LF> Delay: (1) seconds and number of values (3)
<b>aC1!</b>	Start Concurrent Measurement Measures internal temperature	a00101<CR><LF> Delay: (1) seconds and number of values (1)
<b>aCC!</b>	Start Concurrent Measurement and request CRC Measures wind speed and calculates CRC	Simple mode: measurement of momentary wind speed a00601<CR><LF> Delay: (6) seconds and number of values (1) Advanced mode 1&2: measurement of average -, maximum – and minimum wind speed a00103<CR><LF> Delay: (1) seconds and number of values (3)
<b>aCC1!</b>	Start Concurrent Measurement and request CRC Measures internal temperature and calculates CRC	a00101<CR><LF> Delay: (1) seconds and number of values (1)
<b>aD0!</b>	Get Measurement Result(s)	Upon issuing the aD0! Command, the TBSWS1 will send the measurement results. The response format depends on the measurement command issued before.
<b>aV!</b>	Start Verification	a0000<CR><LF> Not supported
<b>aRn! aRCn!</b>	Continuous Measurement Continuous Measurement + CRC	a<CR><LF> Not supported

Table 3 – Standard SDI-12 commands

## SDI-12 ANEMOMETER

### 4.1 Supported Extended Commands

Command	Description	Response
<b>aXSASF,+a.aaa!</b>	<p>Set multiplier</p> <p>The scaling factor consists of sign and up to seven digits with the decimal point at any position. The scaling factor is a multiplicator applied to convert the default output of meters/second into any other unit. The default scaling factor is 1.</p> <p>+a.aaa = 0.278 output in km/h +a.aaa = 0.514 output in knots +a.aaa = 0.447 output in mph</p>	aX_ok<CR><LF>
<b>aXGASF!</b>	Query multiplier	a+a.aaa <CR><LF>
<b>aXCT,+a.aa!</b>	<p>Temperature calibration</p> <p>+a.aa: room temperature where put the boards</p>	aX_ok<CR><LF>
<b>aXTUu!</b>	<p>Set temperature unit</p> <p>u = F for [°C], u = f for [°F]</p>	aX_ok<CR><LF>
<b>aXGU!</b>	Query temperature unit	a,u<CR><LF>
<b>aXSC,+a.aaa!</b>	<p>Set calibration factor</p> <p>Default value is 0,995m/s per revolution/second. Do not change this value</p>	aX_OK<CR><LF>
<b>aXGC!</b>	Query calibration factor	a+0.995<CR><LF>
<b>aXSO,+a.aa!</b>	<p>Set offset value</p> <p>Default value is 0,5m/s; this value represents the starting threshold for wind speed measurement</p>	aX_OK<CR><LF>
<b>aXGO!</b>	Query offset value	a+a.aa <CR><LF>
<b>aXSPPR,n.nn!</b>	<p>Set number of pulses per revolution</p> <p>Default value is 256</p>	aX_OK <CR><LF>
<b>aXGPPR!</b>	Query number of pulses per revolution	a+n.nn <CR><LF>
<b>aXSAMm!</b>	<p>Set mode for anemometer</p> <p>m = 0: simple mode, measurement of momentary wind speed m = 1: Advanced mode 1, measurement of average -, maximum- and minimum wind speed m = 2: Advanced mode 2, measurement of average, maximum and minimum wind speed over 2 consecutive SDI-12 measurements</p>	aX_OK <CR><LF>
<b>aXGAM!</b>	Query anemometer mode	a,m<CR><LF>
<b>aXSAP,+tt!</b>	<p>Set averaging period</p> <p>Default value is 9 seconds, this value must be a multiple of 3 seconds Value: 3, 6, 9 ....60 seconds</p>	aX_OK <CR><LF>
<b>aXGAP!</b>	Query averaging period	a+tt <CR><LF>
<b>aXSLP,+tt!</b>	<p>Set logging period</p> <p>Default value is 900 seconds (15 minutes) Value 60 seconds to 3600 seconds</p>	aX_OK <CR><LF>
<b>aXGLP!</b>	Query logging period	a+tt <CR><LF>

Table 4 – Extended SDI-12 Commands

## SDI-12 ANEMOMETER

### 5 Ordering Information

Part Number	Description
TBSWS1	TBSWS1, Anemometer with 3m cable

Please mention in your order, if you require a different cable length

*Table 5 – Ordering Information*

### 6 History

Version	Date	Author	Changes
V1.0	18.08.2013	Mayerhofer	Creation of the document
V1.1	6.03.2015	Mayerhofer	Chapter 1.1 corrected
V1.2	23.08.2016	Mayerhofer	Correction: revolution ->revolution/s
V1.3	23.08.2016	Mayerhofer	Correction: 3.2 Cable Connection
V1.4	05.11.2020	Philippe Hervieu	Advanced mode 2 added.
V1.5	06.11.2020	Philippe Hervieu	Fix typo mistakes and errors in some SDI-12 commands format.
V1.6	03.03.2020	Philippe Hervieu	Update SDI-12 measurement commands format
V1.7	30.03.2021	Philippe Hervieu	Update some SDI-12 timing information

*Table 6 – History*